

Tubi circolari autoportanti a bicchiere - Lunghezza utile mt. 2

TUBI

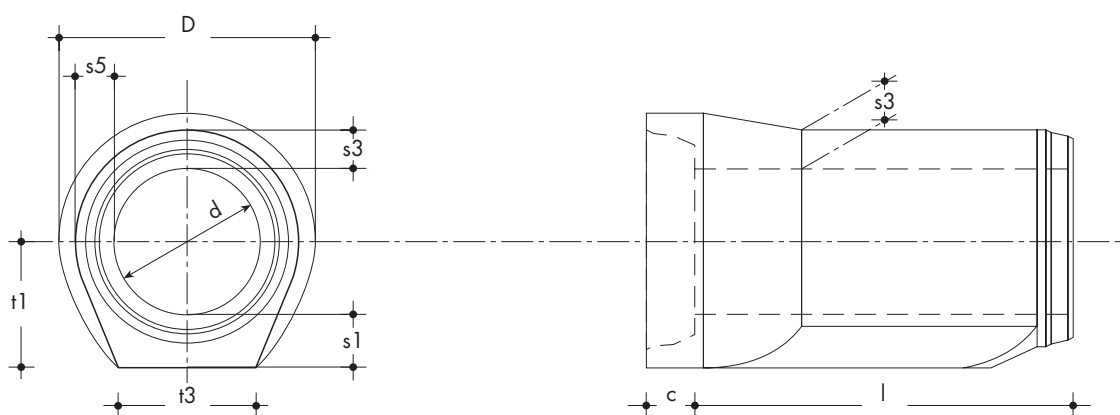

CODICE PRODOTTO			d Ø int cm	l lungh. utile cm	PESO cad. kg	s1 mm	s3 mm	s5 mm	t1 mm	t3 mm	D mm	C mm
NON ARMATI	RINFORZATI CON FIBRE	FIBRO- ARMATI + RESINA										
TB30	TBA30	TBAE30	30	200	310	55	55	55	246	-	492	95
TB40	TBA40	TBAE40	40	200	400	55	55	55	300	-	600	95
TB50	TBA50	TBAE50	50	200	700	100	63	55	350	400	730	95
TB60	TBA60	TBAE60	60	200	920	115	75	63	415	450	860	110
TB80	TBA80	TBAE80	80	200	1500	138	95	79	538	550	1116	110
TB100	TBA100	TBAE100	100	200	2320	164	115	95	664	650	1388	126
TB120	TBA120	TBAE120	120	200	3000	181	131	107	781	730	1632	126

CODICE PRODOTTO GUARNIZIONI	d Ø INTERNO cm	GIUNTO GOMMA Ø mm	SVILUPPO GIUNTO mm
G30	30	16	1035
G40	40	16	1335
G50	50	16	1665
G60	60	20	1980
G80	80	20	2635
G100	100	22	3280
G120	120	22	3915

Tubi nei diametri cm 30 e 40 senza piano di posa.
Tubi dal diametro 50 al 120 cm con piano di posa

- guarnizione di gomma a rotolamento
- rivestimenti interni effettuati con resine epossidiche
- tubi fibroarmati